

ITEM NO.	PART NUMBER	DESCRIPTION	QTY.
1	P17031	SPREADER BAR FOR F350CT	1
2	P17007	M10 PIN WITH KEY RING	1
3	P17006	RED, PLASTIC MAST-BOOM JOINT COVER	1
4	P17008	M10 QUICK RELEASE PIN	1
5	P17005	STAND, STAND RUBBER GRIP, AND HARDWARE	1

PGS-230 Attachment XI – F350CT SERVICE PARTS DRAWING

ITEM NO.	PART NUMBER	DESCRIPTION	QTY.
1	P16794	3" FRONT REPLACEMENT CASTER	1
2	P16795	REAR CASTER WITH LOCK 4", GRAY	1
3	P17000	M12 CARRIAGE BOLT, WASHER, AND LOCKNUT	1
4	P17020	RED FRONT CASTER COVER	1
5	P17021	RED REAR CASTER COVER	1
6	P17002	LEG OPENING LINKAGE KIT	1
7	P17001	FOOTPEDAL KIT	1

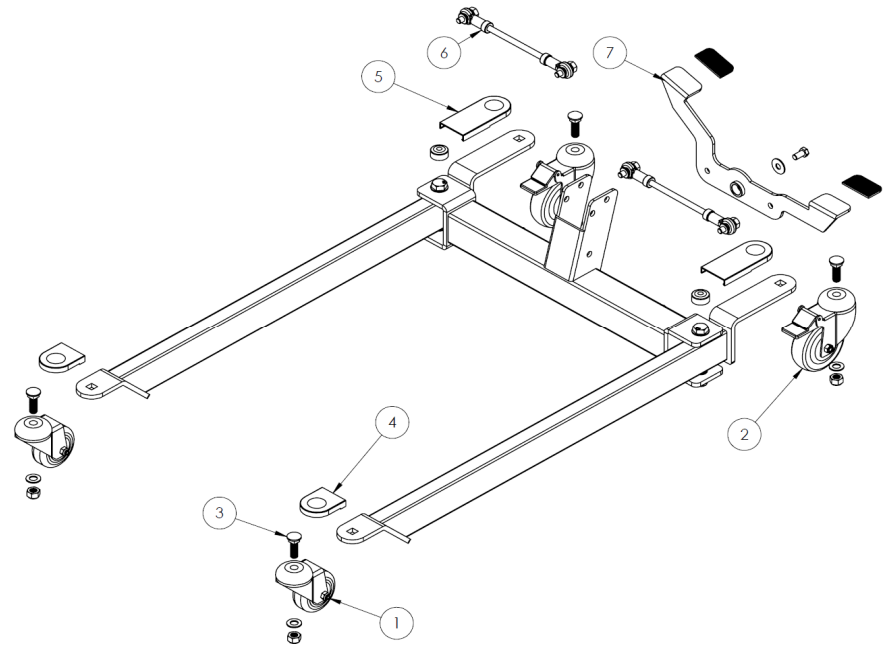

ITEM NO.	PART NUMBER	DESCRIPTION	QTY.
1	P16814	FLOOR LIFT ACTUATOR F350CT AND F400	1
2	P11620	FLOOR LIFT HAND PENDANT REPLACEMENT	1
3	P16693	FLOOR LIFT CONTROL BOX MAST BRACKET	1
4	P17012	2 PCS - M4 SCREWS, 2 PCS - M5 SCREWS	1
5	P16694	FLOOR LIFT CONTROL BOX ONLY	1
6	P11618	FLOOR LIFT BATTERY PACK 24V	1
7	P11619	FLOOR LIFT AC CHARGER	1

