

ITEM NO.	PART NUMBER	DESCRIPTION	QTY.
1	P17058	6-PT SPREADER BAR F500P	1
2	P17007	M10 PIN WITH KEY RING	1
3	P17017	HEX BOLT M10 20L	1
4	P17029	HANDLE, LEG OPENING	1

**PGS-230 Attachment VIII – F500P SERVICE PARTS DRAWING**

ITEM NO.	PART NUMBER	DESCRIPTION	QTY.
1	P17025	CASTER, DUAL FRONT, 3" RED	1
2	P17026	REAR CASTER WITH LOCK, 4", RED	1
3	P17004	M12 CARRIAGE BOLT AND LOCKNUT	1
4	P16856	LINKAGE KIT FOR F500S & F500P	1

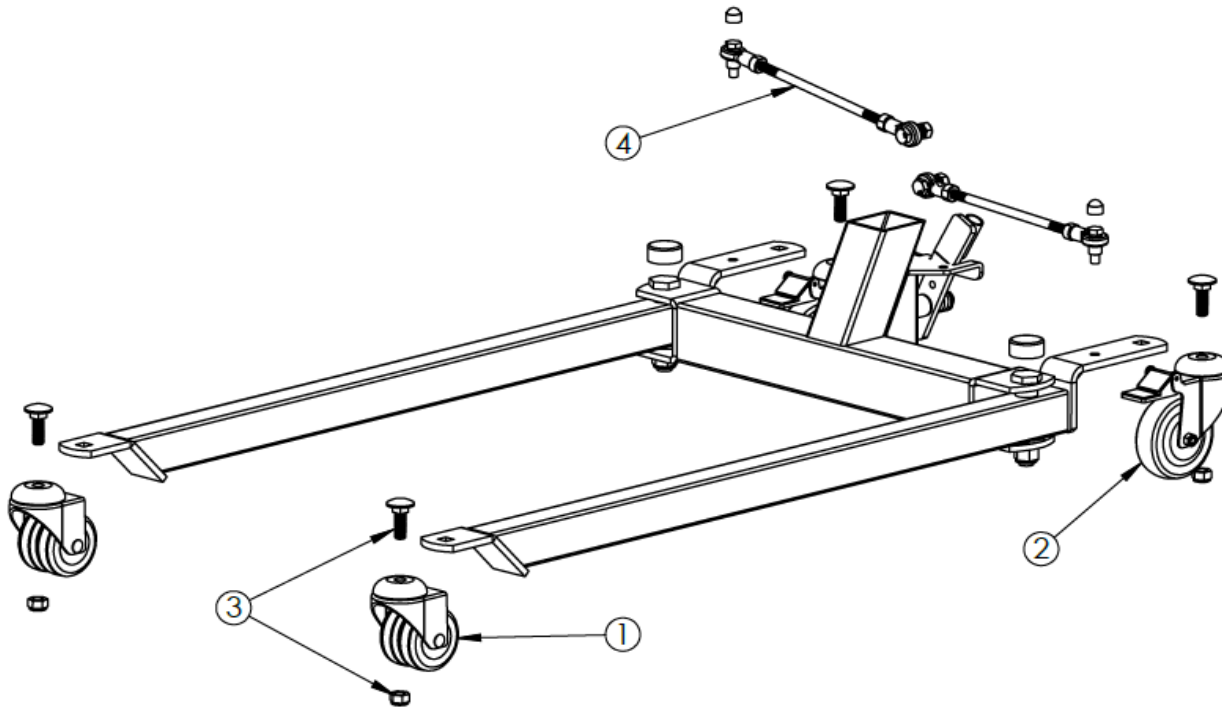

ITEM NO.	PART NUMBER	DESCRIPTION	QTY.
1	P16691	FLOOR LIFT ACTUATOR FOR F500P	1
2	P11620	FLOOR LIFT HAND PENDANT REPLACEMENT	1
3	P16693	FLOOR LIFT CONTROL BOX MAST BRACKET	1
4	P17012	2 PCS - M4 SCREWS, 2 PCS - M5 SCREWS	1
5	P16694	FLOOR LIFT CONTROL BOX ONLY	1
6	P11618	FLOOR LIFT BATTERY PACK 24V	1
7	P11619	FLOOR LIFT AC CHARGER	1

